

Part number

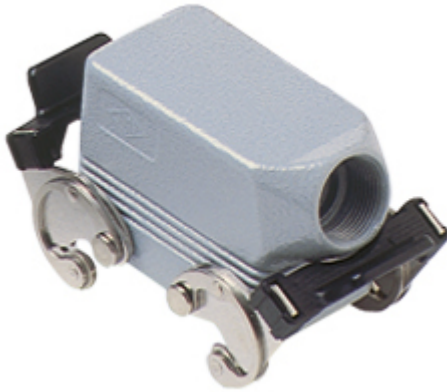

CAO 10 X29



Brief description:

hoods with two levers, size "57.27", side entry, Pg29, metal version, IP66 (EN 60529) and IP69K (DIN 40050 - 9) degree of protection.

| Product description | |
|---------------------------|------------------------------------|
| Version | metal version |
| Series | Hoods for 2 levers, without gasket |
| Product type | with 2 levers, without gasket |
| Variant | side entry |
| Style | high construction |
| Family | CLASS enclosures |
| Size | size "57.27" |
| Technical data | |
| Material | metal |
| IP degree of protection | IP66 (and IP69K DIN 40050 - 9) |
| Cable entry | Pg29 |
| Further technical details | |
| Weight | 275,00 g |

| Approvals / Standards | |
|------------------------------|---|
| Quality mark |  (type:4/4X/12),  , EAC |
| Conformity | CQC, CE |
| General ordering information | |
| EAN13 code | 8015747006163 |
| Tariff number | 85369095 |
| Packaging Information | |
| Packaging length | 250,00 mm |
| Packaging height | 145,00 mm |
| Packaging width | 300,00 mm |
| Packaging weight | 2,75 kg |
| Packaging volume | 10,88 dm ³ |
| Packaging description | Carton box |
| Packaging quantity | 10 Pcs |
| Packaging EAN code | 8015747215565 |
| Sub-packaging weight | 1,38 kg |
| Sub-packaging description | Plastic pakaging |
| Sub-packaging quantity | 5 Pcs |
| Sub-packaging EAN barcode | 8015747006170 |

Part number

CAO 10 X29



Catalogue drawings

CHO X (CAO X) - MHO X (MAO X)

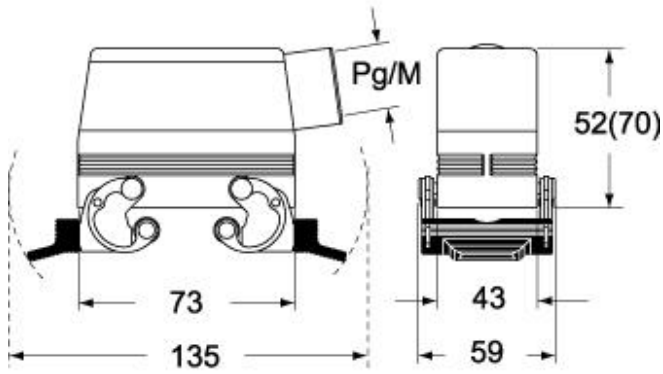

CHV X (CAV X) - MHV X (MAV X)

